

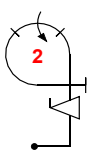
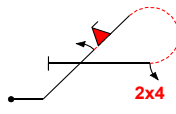
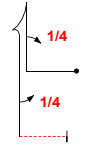
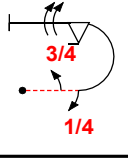
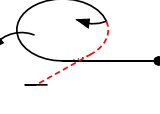
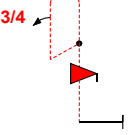
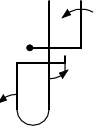

Pilote ID

France Doret/excellence inconnu

Vol N°

No	Symbol	Cat. No.	K	Total K	Grade	Pos	Remarks	Item	K	Grade
1		8.6.1.1 9.9.1.4 9.2.3.4	11 15 9	35	.			Pos.	35	
								Harm.	0	
2		8.5.3.1 9.1.2.2 9.10.2.2 9.4.3.2	12 6 15 5	38	.			Fig K	Total K	
								350	385	
3		6.2.1.3 9.1.1.1 9.1.5.1	16 6 2	24	.			Penalties		
								Trop Bas		
4		7.2.4.2 9.1.3.3 9.1.3.1 9.9.3.2 9.1.3.8	6 6 2 11 12	37	.			Trop Haut		
								Insertions		
5		2.3.3.3	38	38	.			Echauf. non OK		
								Battem. d'Ailes		
6		8.4.2.2 9.1.1.3 9.10.5.4	17 10 13	40	.			Disqualifié		
								Autre(noter...)		
7		8.8.2.1 9.1.1.4 9.1.5.2 9.1.1.2	19 12 4 8	43	.			Final Freestyle		
								Duration	Min	Sec
8		8.6.3.3 9.11.1.6 9.2.3.8	13 3 15	31	.			Judges Details		
								Signature		
9		5.3.2.4 9.4.2.2 9.8.1.1 9.8.5.1	21 7 7 3	38	.			Name		
								Number		
10		8.4.14.1 9.1.2.4 9.1.4.2	12 10 4	26	.					

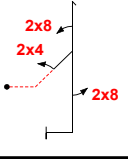
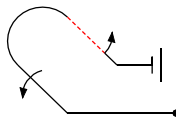
Pilote
Avion

Pilote ID

France Doret/excellence inconnu

Vol N°

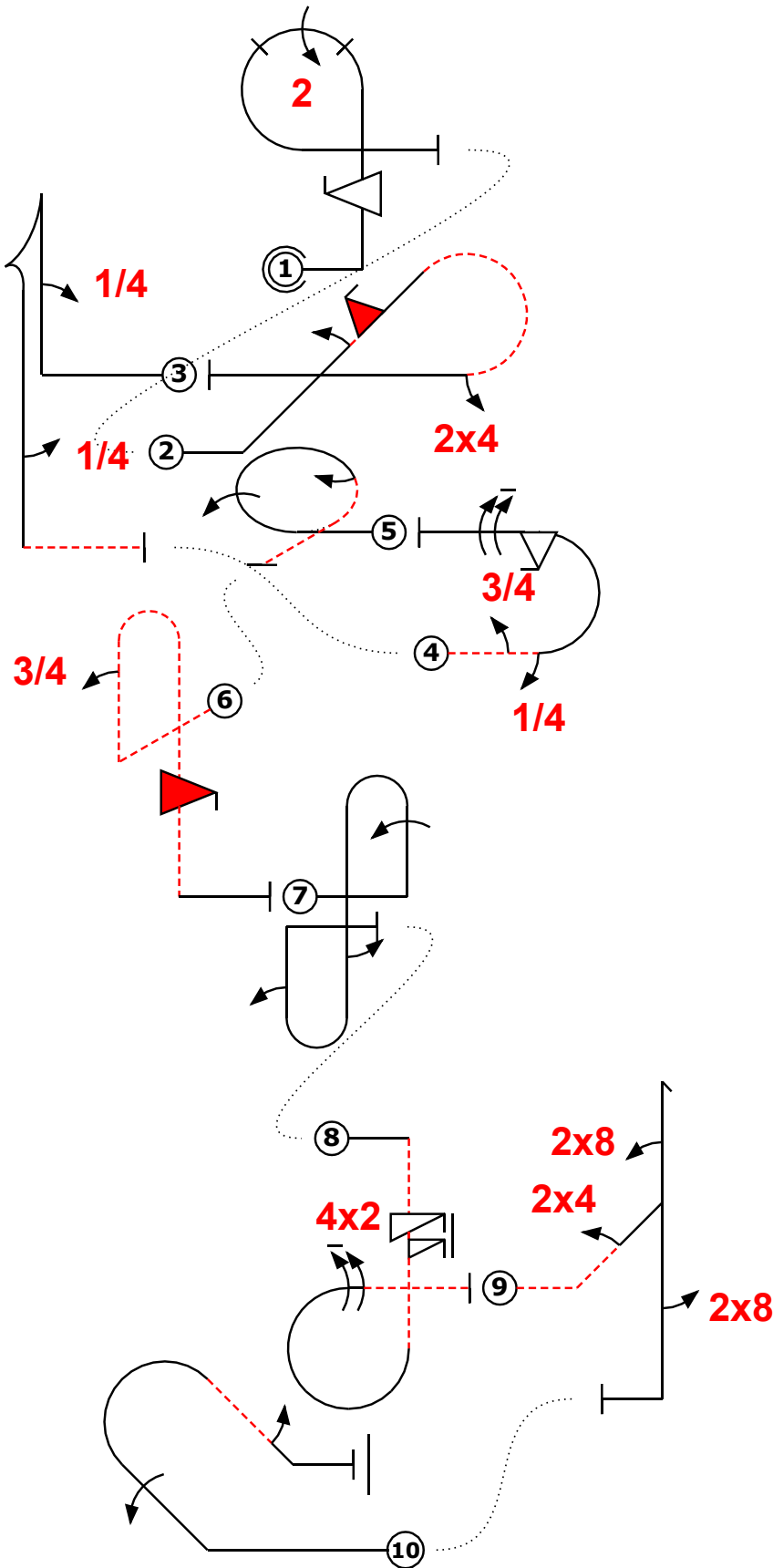

Avion			
Fig	Aresti	K	
1	8.6.1.1	11	35
	9.9.1.4	15	
	9.2.3.4	9	
2	8.5.3.1	12	38
	9.1.2.2	6	
	9.10.2.2	15	
	9.4.3.2	5	
3	6.2.1.3	16	24
	9.1.1.1	6	
	9.1.5.1	2	
4	7.2.4.2	6	37
	9.1.3.3	6	
	9.1.3.1	2	
	9.9.3.2	11	
	9.1.3.8	12	
5	2.3.3.3	38	38
6	8.4.2.2	17	40
	9.1.1.3	10	
	9.10.5.4	13	
7	8.8.2.1	19	43
	9.1.1.4	12	
	9.1.5.2	4	
	9.1.1.2	8	
8	8.6.3.3	13	31
	9.11.1.6	3	
	9.2.3.8	15	
9	5.3.2.4	21	38
	9.4.2.2	7	
	9.8.1.1	7	
	9.8.5.1	3	
10	8.4.14.1	12	26
	9.1.2.4	10	
	9.1.4.2	4	
Total K = 350 (max K = 350)			

Pilote
Avion

Pilote ID

France Doret/excellence inconnu

Vol N°

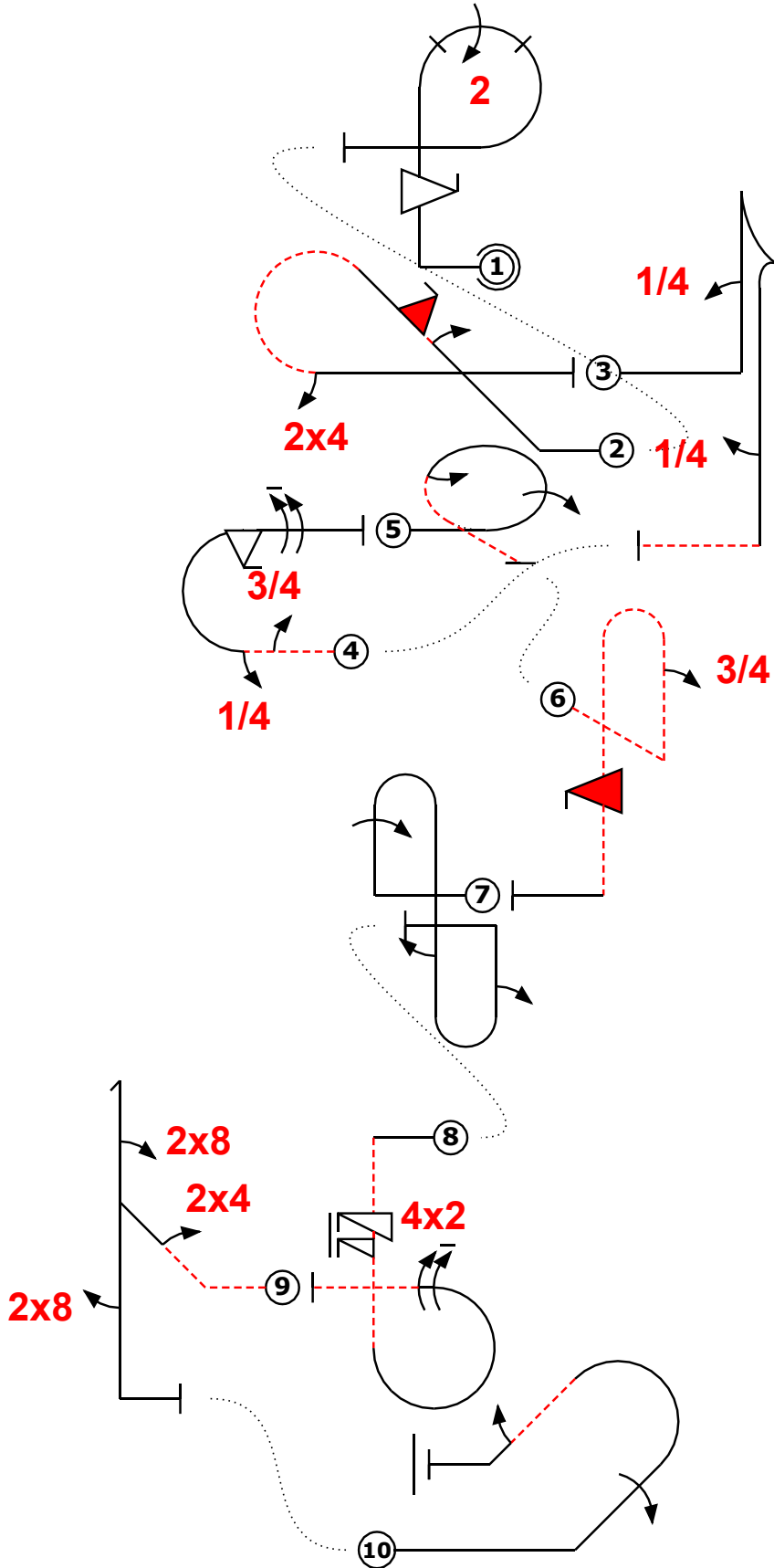

Avion			
Fig	Aresti	K	
1	8.6.1.1	11	35
	9.9.1.4	15	
	9.2.3.4	9	
2	8.5.3.1	12	38
	9.1.2.2	6	
	9.10.2.2	15	
	9.4.3.2	5	
3	6.2.1.3	16	24
	9.1.1.1	6	
	9.1.5.1	2	
4	7.2.4.2	6	37
	9.1.3.3	6	
	9.1.3.1	2	
	9.9.3.2	11	
	9.1.3.8	12	
5	2.3.3.3	38	38
6	8.4.2.2	17	40
	9.1.1.3	10	
	9.10.5.4	13	
7	8.8.2.1	19	43
	9.1.1.4	12	
	9.1.5.2	4	
	9.1.1.2	8	
8	8.6.3.3	13	31
	9.11.1.6	3	
	9.2.3.8	15	
9	5.3.2.4	21	38
	9.4.2.2	7	
	9.8.1.1	7	
	9.8.5.1	3	
10	8.4.14.1	12	26
	9.1.2.4	10	
	9.1.4.2	4	
Total K = 350 (max K = 350)			

Pilote
Avion



Figure K
350
K total
385

Nom des Juges	
Signature	Numéro

Vol N°

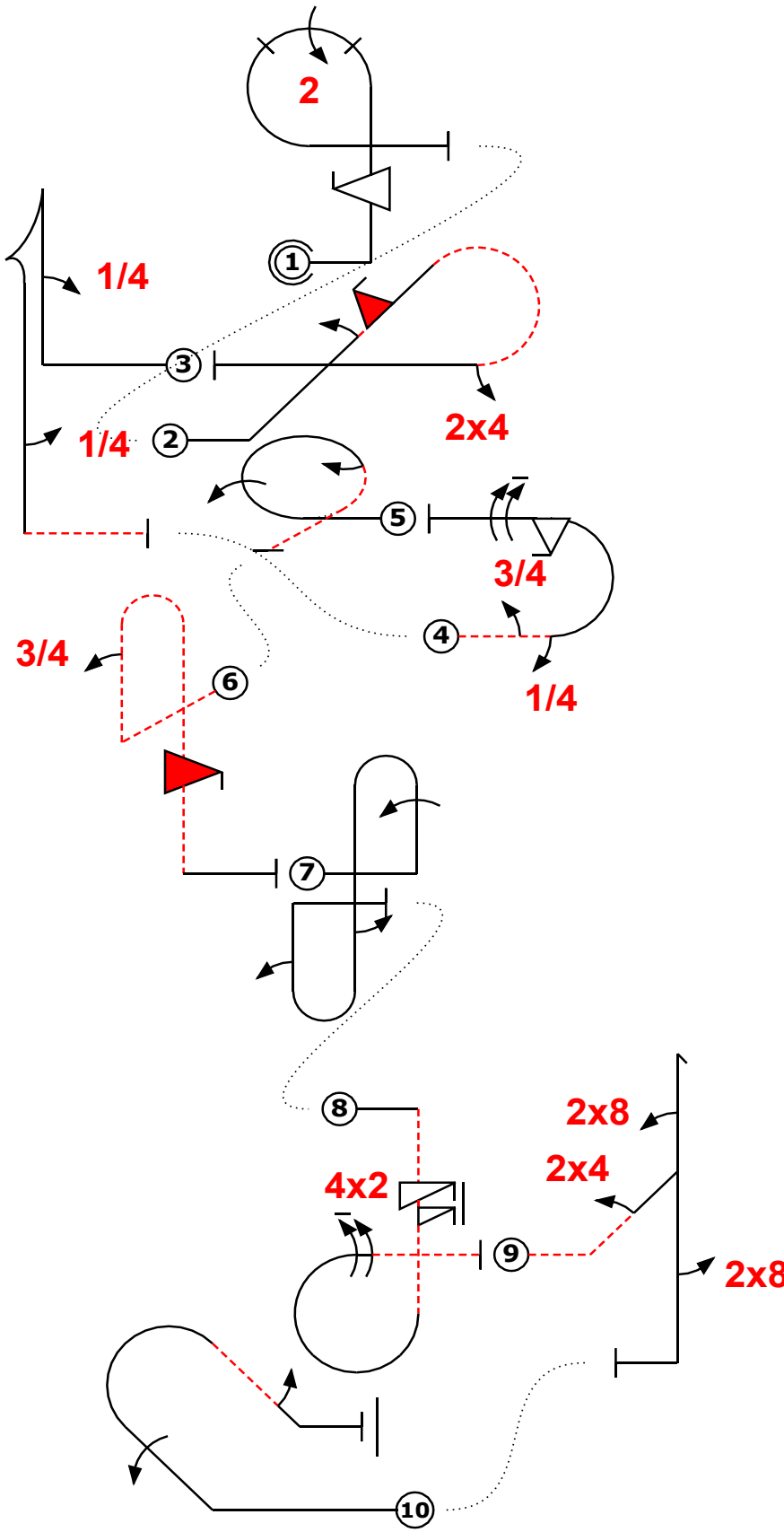

Fig	Grade	Pos	Remarks
1	.		
2	.		
3	.		
4	.		
5	.		
6	.		
7	.		
8	.		
9	.		
10	.		

Cadre(Coef)
35

Trop Bas		Echauf. non OK	
Trop Haut		Battem. d'Ailes	
Interruptions		Disqualifié	
Insertions		Autre(noter...)	

Fig 1	K	Fig 2	K	Fig 3	K	Fig 4	K	Fig 5	K	Fig 6	K	Fig 7	K	Fig 8	K	Fig 9	K	Fig 10	K
8.6.1.1	11	8.5.3.1	12	6.2.1.3	16	7.2.4.2	6	2.3.3.3	38	8.4.2.2	17	8.8.2.1	19	8.6.3.3	13	5.3.2.4	21	8.4.14.1	12
9.9.1.4	15	9.1.2.2	6	9.1.1.1	6	9.1.3.3	6			9.1.1.3	10	9.1.1.4	12	9.11.1.6	3	9.4.2.2	7	9.1.2.4	10
9.2.3.4	9	9.10.2.2	15	9.1.5.1	2	9.1.3.1	2			9.10.5.4	13	9.1.5.2	4	9.2.3.8	15	9.8.1.1	7	9.1.4.2	4
		9.4.3.2	5			9.9.3.2	11					9.1.1.2	8			9.8.5.1	3		
	35		38		24		37		38		40		43		31		38		26

Pilote:

Avion:

Equipe: FRA

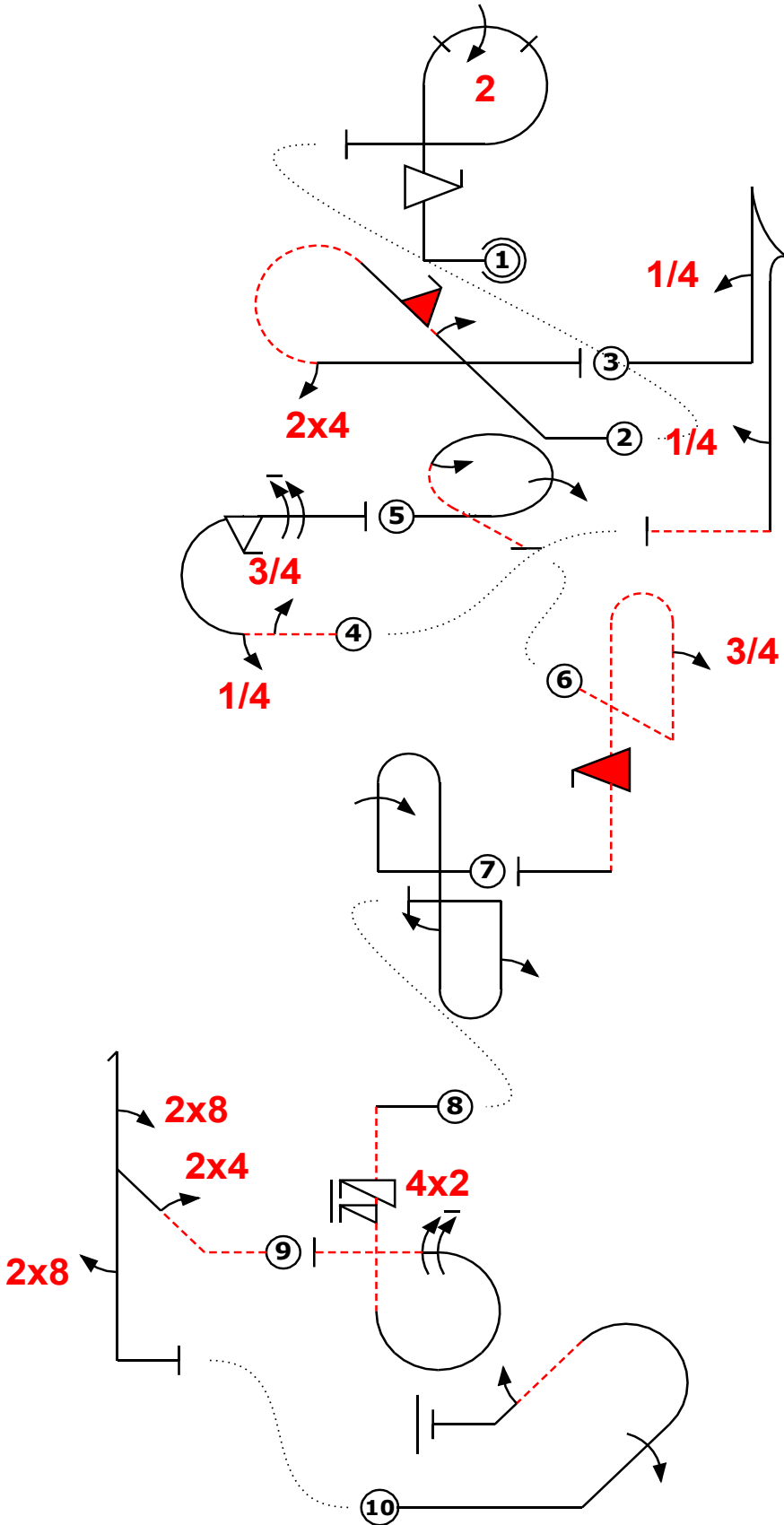

Fig	Grade	Pos	Remarks
1	.		
2	.		
3	.		
4	.		
5	.		
6	.		
7	.		
8	.		
9	.		
10	.		

Cadre(Coef)	
35	.

Trop Bas		Echauf. non OK	
Trop Haut		Battem. d'Ailes	
Interruptions		Disqualifié	
Insertions		Autre(noter...)	

Fig 1	K	Fig 2	K	Fig 3	K	Fig 4	K	Fig 5	K	Fig 6	K	Fig 7	K	Fig 8	K	Fig 9	K	Fig 10	K
8.6.1.1	11	8.5.3.1	12	6.2.1.3	16	7.2.4.2	6	2.3.3.3	38	8.4.2.2	17	8.8.2.1	19	8.6.3.3	13	5.3.2.4	21	8.4.14.1	12
9.9.1.4	15	9.1.2.2	6	9.1.1.1	6	9.1.3.3	6			9.1.1.3	10	9.1.1.4	12	9.11.1.6	3	9.4.2.2	7	9.1.2.4	10
9.2.3.4	9	9.10.2.2	15	9.1.5.1	2	9.1.3.1	2			9.10.5.4	13	9.1.5.2	4	9.2.3.8	15	9.8.1.1	7	9.1.4.2	4
		9.4.3.2	5			9.9.3.2	11					9.1.1.2	8			9.8.5.1	3		
	35		38		24	9.1.3.8	12		38		40		43		31		38		26

Pilote:

Avion:

Equipe: FRA

VENT

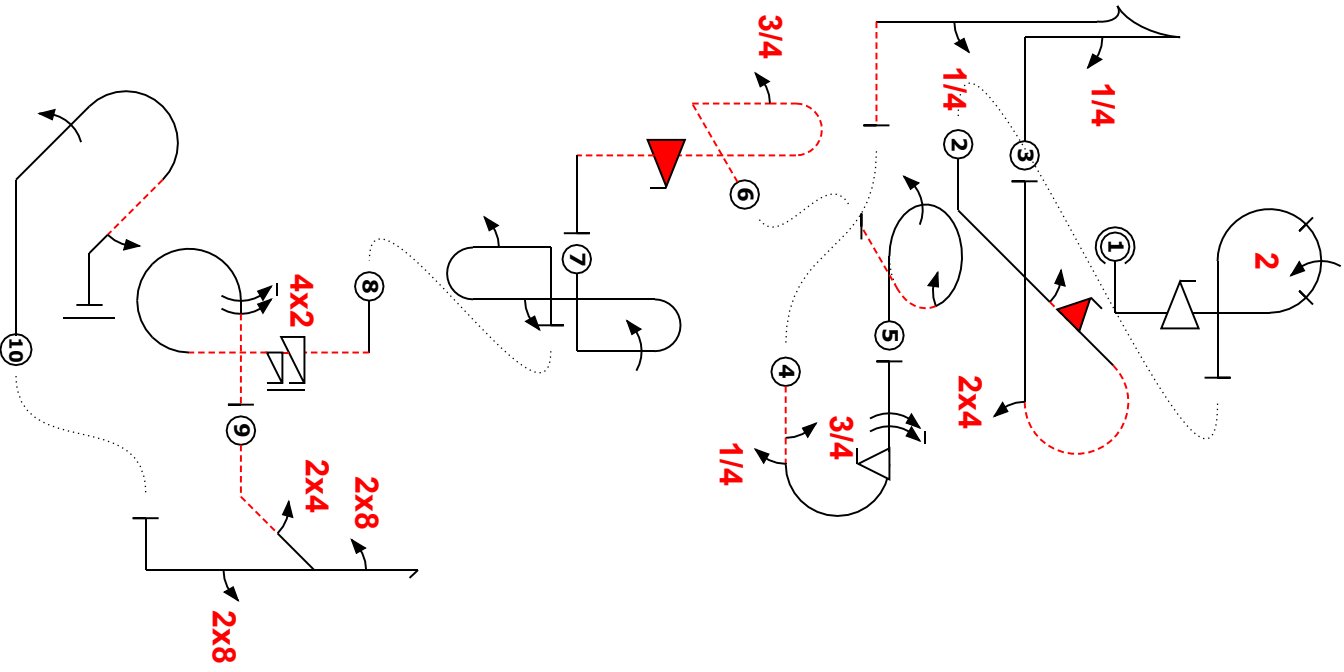

VENT

